



VSB

OUTDOOR VACCUUM BREAKER

The VSB outdoor circuit breaker designed for and build in North America delivers reliable and safe performances.

Standard Features

- Trip and close coil
- Visual circuit breaker status window
- Operation counter
- Mechanical position indicator
- External manual trip handle
- Fused knife-switched control voltage disconnects
- Porcelain dry-type bushings
- NEMA 3R Bolted Welded cabinet construction
- Permanent lifting eyes (4)
- Adjustable Hot-Dip galvanized Support 4 (9 positions)
- Corrosion resistant power paint finish (ANSI-61 light grey)
- Cabinet heaters to prevent condensation
- Additional heaters for -50°C (122 F)
- Arc proof (IEEE C37.20.7 Type 2B)

Especially designed for the toughest climatic conditions, easy operation and enhanced personnel safety.

OPTIONS & CUSTOMIZATION

- Terminal connectors for bushings
- Bushing (polymer or porcelaine)
- Bushing size (small, medium or long)
- Special Current transformers class
- Cabinet controls
- Second trip coil
- Undervoltage trip device
- Seismic capability (IEEE 693 high level)
- Voltage (low or medium)
- Ventilation filters

Distribution circuit breakers are essential components of medium-voltage outdoor distribution grid.

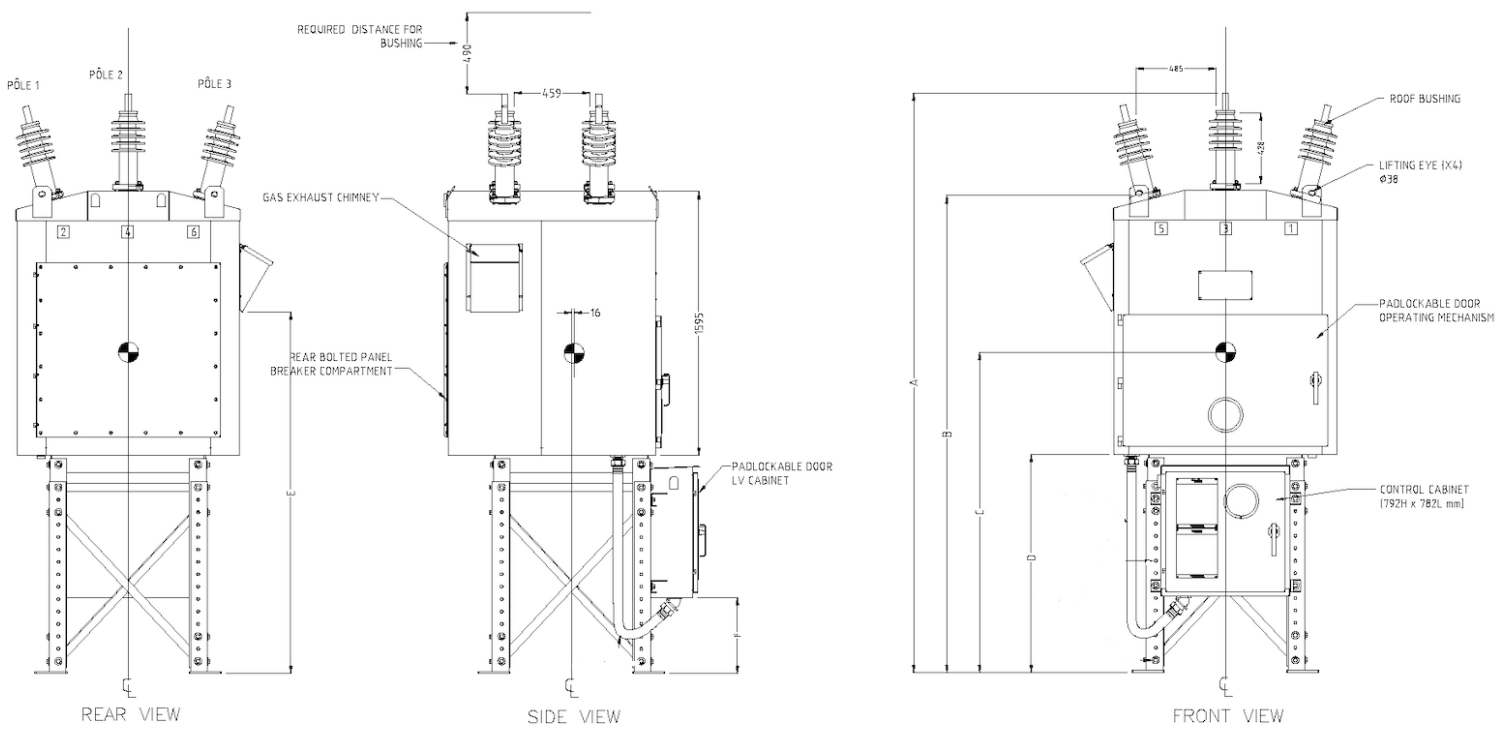

Technical Characteristics		
Nominal Current	A	1200 / 2000 / 2500
Rated maximum voltage	kVrms	15 / 29.8
Power frequency withstand voltage	kVrms	50 / 60
Lightning impulse level	kVp	150
Short-circuit interrupting current (sym.)	kA	12.5 / 25 / 31.5
DC component (asymmetry)	ms	45 / 75
Short-circuit time withstand current (1s)	kA	25 / 31.5
Standard operating duty		O-0.3s-CO-15s-CO
Maximum interrupting time		3.5 cycles
Control voltage	Vdc	24, 48, 125, 250
	Vac	120, 240
Environment		
Operating temperature range	°C	- 50 to + 40
	(F)	(-58 to 104)
Relative humidity	%	0 - 100
Altitude	m / ft	1,000 / 3,280
	G	0.5 / 1

POS	ADJUSTABLE SUPPORT			
	A	B	C	D
1	3500(137.8)	2879(113.3)	1933(76.1)	1316(51.8)
2	3575(140.7)	2954(116.3)	2008(79)	1391(54.8)
3	3650(143.7)	3029(119.3)	2083(82)	1466(57.7)
4	3725(146.7)	3104(122.2)	2158(85)	1541(60.7)
5	3800(149.6)	3179(125.2)	2233(87.9)	1616(63.6)
6	3875(152.6)	3254(128.1)	2308(90.9)	1691(66.6)
7	3950(155.5)	3329(131.1)	2383(93.8)	1766(69.5)
8	4025(158.5)	3404(134)	2458(96.8)	1841(72.5)
9	4100(161.4)	3479(137)	2533(99.7)	1919(75.4)

The VSB can be easily customized to suit the specific needs of network modernisation and future-oriented smart grids.

Versatile Protection for Your Power Distribution Needs

The VSB is a versatile and highly customizable enclosure solution designed to safeguard your critical electrical equipment.

Engineered for demanding utility and industrial applications, the VSB can be tailored to the unique requirements of your specific site and power distribution system.

A Personalized Approach to Power Protection

With the VSB, you're not limited to a one-size-fits-all solution. CO7 Technologies works closely with you to engineer a VSB that seamlessly integrates with your existing infrastructure and operational needs. This personalized approach ensures maximum protection, performance, and value for your power distribution assets.



2525, Louis A. Amos
 Montreal, QC, Canada H8T 1C3
 (866) 267-0045
 info@CO7Tech.com
 www.CO7Tech.com CO7