



VRuptS

Where Safety Meets Reliability

CO7 Technologies has engineered the VRuptS polymer cutout with a hydrophobic silicone rubber insulator that is lightweight, strong, and exceptionally durable, particularly in harsh climates. This innovative cutout, resistant to mechanical failure, enhances the reliability and protection of lines and systems, including transformers.

Silicone Polymer

The VRuptS composite insulator, crafted with high-performance silicone rubber, provides exceptional resistance to tracking and weathering.

Rigorous Testing

The exceptional quality and durability of the VRuptS are supported by extensive testing, ensuring it meets and surpasses all necessary standards for cutouts.

Lightweight Construction

With its polymer insulator, the VRuptS is more resistant and weighs significantly less than traditional porcelain cutouts. This makes it easier to handle and reduces the risk of damage during installation.

Increased Insulation Distance

The VRuptS offers a significantly greater metal-to-metal leakage distance compared to porcelain cutouts, enhancing electrical performance and safety.

Industry-Standard Compatibility

The VRuptS seamlessly integrates with fuse products from various suppliers, providing customers with greater flexibility and interoperability.

- Long experience in designing, assembling and testing in North America
- Short lead times
- Local inventory to meet delivery needs
- Interchangeability with major manufacturers
- Samples available. Go to [CO7Tech/cutout-sample](#)

The VRuptS cutout is designed to be fuseholder interchangeable with polymer cutouts manufactured by Leading cutout manufacturer.

The V-RuptS has been design and manufactured following ANSI C37.42 "Specification for Distribution Cutouts and Fuse Links".



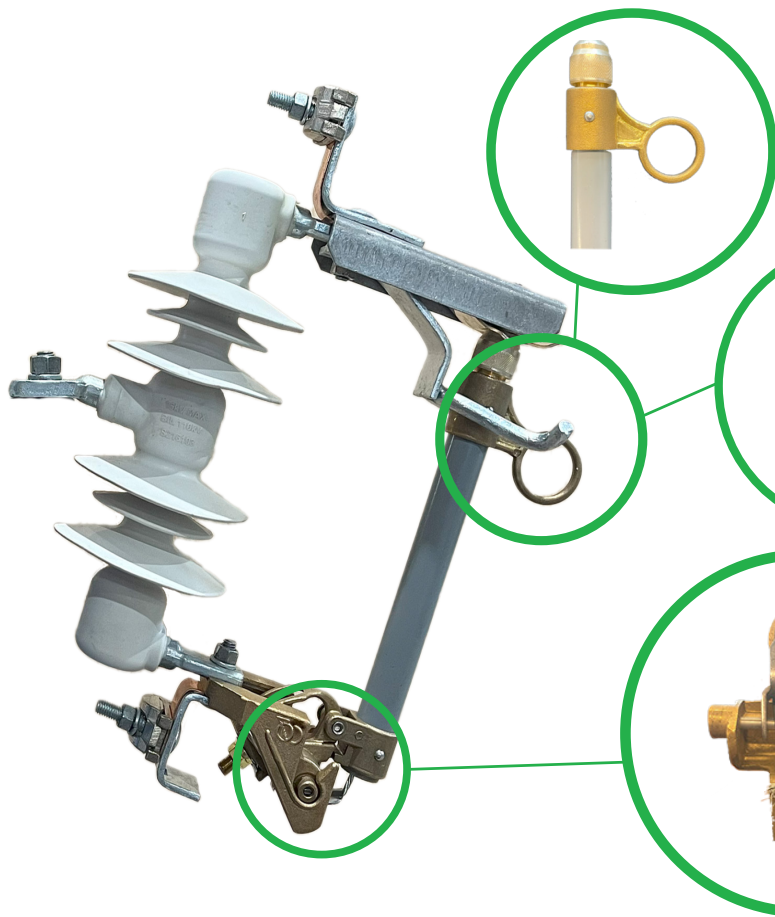

The rounded surface top of the cap helps the Fuse Holder to self centralize and have a proper connection.

Steel hook dedicated for loadbreak tools like the LoadBuster.

The ring acts as a support for opening and closing the Fuse Holder connection.

The fuse tensioning the is responsible for keeping the link tensioned and helps on the expulsion whenever the action is needed.

Continuous Current(A)	100	
Voltage Rating		
kV, Max	15	27
kV, BIL	110	125
Creepage distance		
Inches (mm)	8.50 (216)	21.85 (555)
Insulator	Polymer	
Short-Circuit Interrupting Rating (A RMS)		
Asymmetrical	10,000	12,000
Symmetrical	7,100	8,000
Environmental		
Ambient Temperature	-50°C (-58°F) to +40°C (104°F)	
Altitude	1000m (3280ft)	
Wind Speed	35 m/s	
Peak wind speed	40 m/s	
Humidity	Yes	
Pollution	Yes	
Saline environment	Yes	
Industrial environment	Yes	
Sandstorm	Yes	
Seismic shock	Moderate	

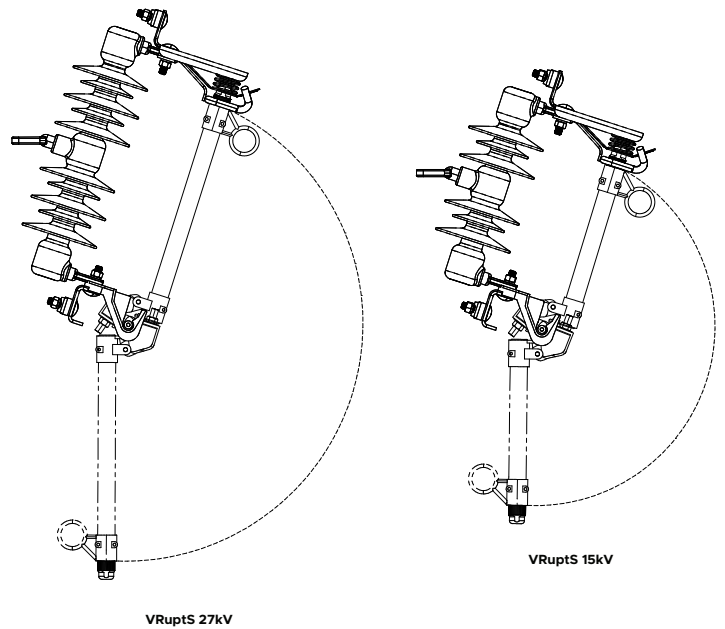

CO7 TECHNOLOGIES
 2525, Louis A. Amos
 Montreal, QC, Canada H8T 1C3
 (866) 267-0045
 info@CO7Tech.com
 www.CO7Tech.com